

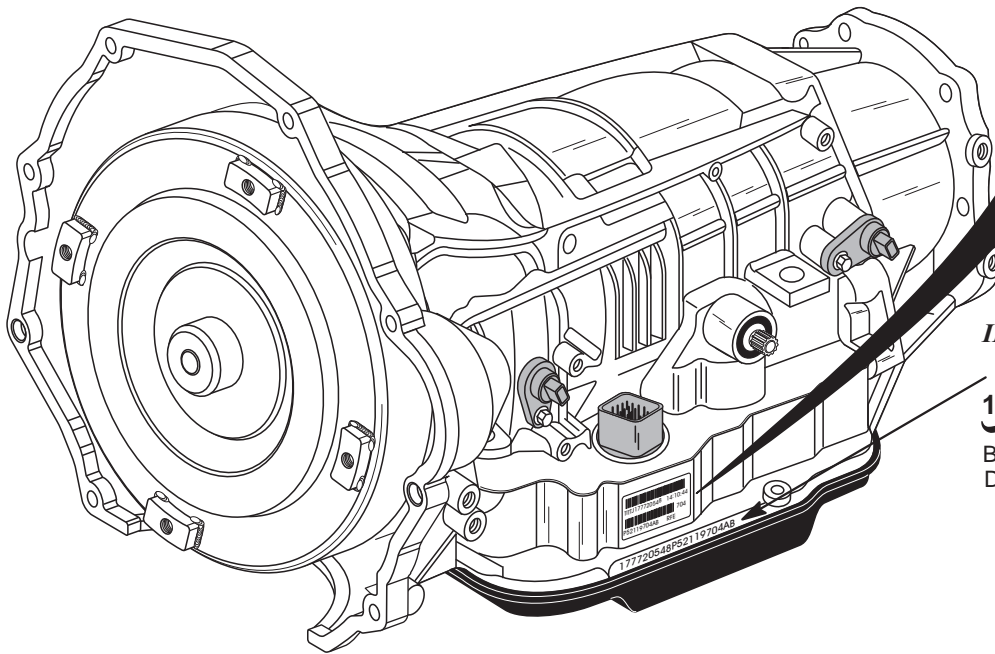

Technical Service Information

DODGE RAM TRUCKS 68RFE TRANSMISSION *FOUND BEHIND 5.9L (L6) and 6.7L Diesel Engines*

Bar Code Label

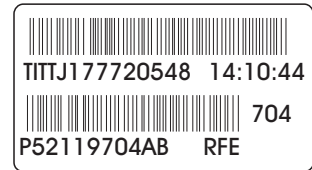

ID Numbers Also Etched Into Case Pan Rail Here

1777	20548	P52119704AB
Build Date	Serial Number	Part Number

- 6 = Six Forward Speeds**
- 8 = Relative Torque Capacity**
- R = Rear Wheel Drive**
- FE = Fully Electronic**

Fluid Requirements
"Mopar® ATF+4"

Copyright © 2011 ATSG

Figure 1

CLUTCH APPLICATION CHART

SELECTOR POSITION	LO/REV CLUTCH	UD CLUTCH	SECOND CLUTCH	OD CLUTCH	FOURTH CLUTCH	REVERSE CLUTCH	LOW SPRAG CLUTCH	GEAR RATIO
PARK	ON							
REVERSE	ON					ON		4.44:1
NEUTRAL	ON							
OD-1ST	ON*	ON					HOLD	3.23:1
OD-2ND		ON	ON					1.83:1
OD-3RD		ON			ON			1.41:1
OD-4TH		ON		ON				1.00:1
OD-5TH				ON	ON			0.81:1
OD-6TH			ON	ON				0.62:1
OD-LIMP		ON		ON				1.00:1
(2)-1ST	ON*	ON					HOLD	3.23:1
(2)-2ND		ON	ON					1.83:1
(2)-LIMP		ON	ON					1.83:1
(1)-1ST	ON	ON					HOLD	3.23:1

* L/R Clutch is on only with the output shaft speed below 150 RPM.

COMPONENT LOCATIONS

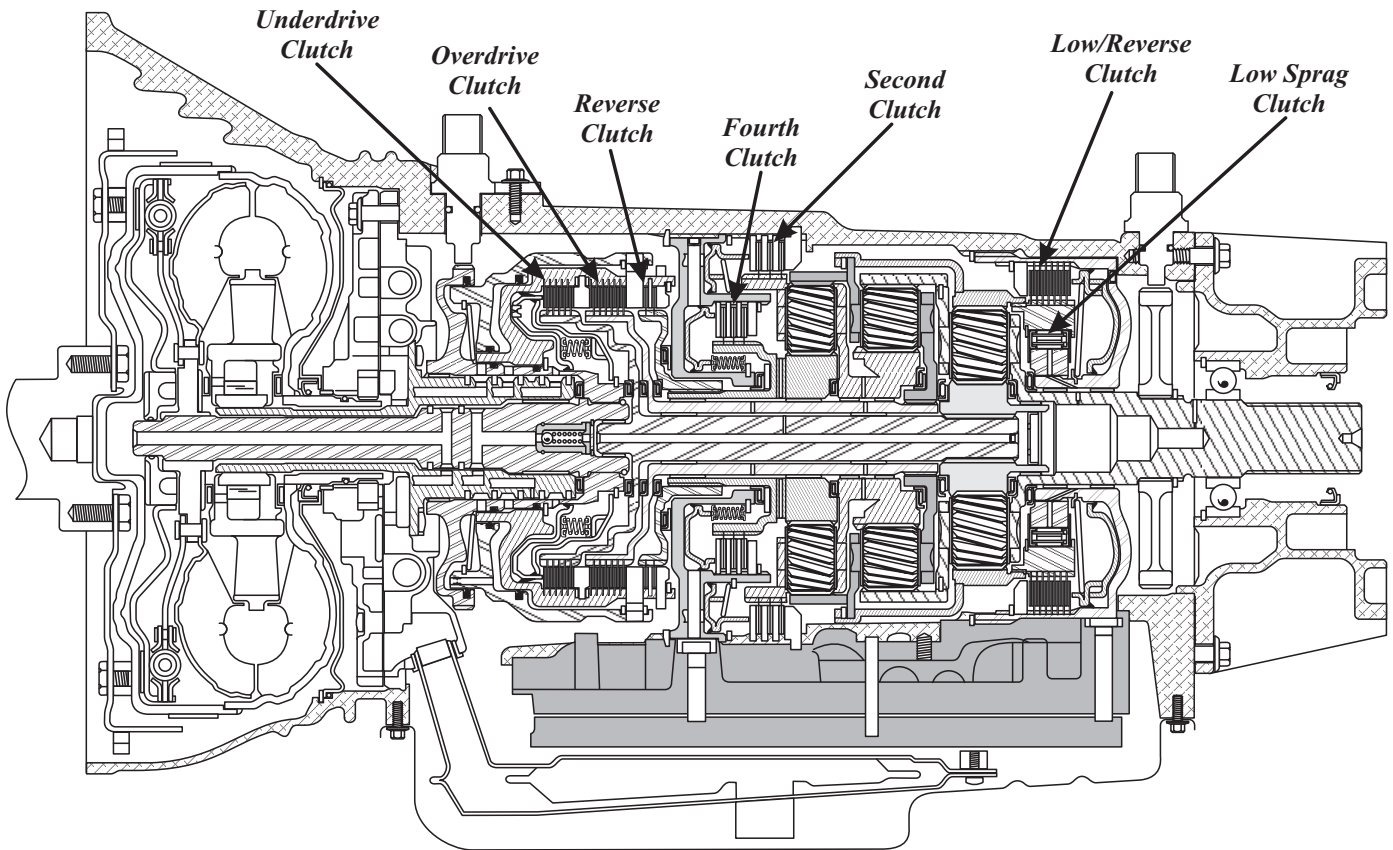

Copyright © 2011 ATSG

Figure 2



Technical Service Information

MECHANICAL OPERATION

The operation of the 68RFE is very similar to the Chrysler 45RFE. Drive range provides reduction 1st, 2nd, and 3rd gear, direct 4th gear and overdrive 5th and 6th gears. The shift into 5th and 6th gear occurs only after the transmission has completed the shift into 4th gear. Upshifts into 5th and 6th gear will be delayed when the fluid temperature is below 4.5°C (40°F) or above 115°C (240°F). The Input Clutch Housing retains the "single-sided" underdrive clutch, "single-sided" overdrive clutch and the reverse clutch. It is set up almost identical to the 41TE transaxle, except much larger. The 68RFE also contains separate holding clutches, such as the 2nd clutch, 4th clutch and the "single-sided" low/reverse clutch. This unit also uses one freewheel device called the low sprag.

To achieve its different gear ratios, the 68RFE applies different combinations of two clutch packs at a time, as shown in Figure 2. In Park and Neutral, only the low/reverse clutch is applied. Refer to the chart in Figure 2 for the clutches that are applied for each shift lever (gear) position.

Another feature of the 68RFE is the three planetary gear sets, as shown in Figure 2, that are all equipped with 6 pinion carriers to accommodate the Diesel engine. These planetary gear sets also provide a deeper 1st and reverse ratio. All gear ratios are also shown in the chart in Figure 2.

SOLENOID OPERATION

Solenoids are used to control the L/R, 2C, 4C, UD and OD friction elements. The Reverse clutch is controlled by the manual valve in the valve body and line pressure. The Multi-Select solenoid is used primarily to provide 3rd gear and reverse "limp-in" operation. The TCM energizes or operates the solenoids individually by grounding the return wire of the solenoid as necessary. When a solenoid is energized, a fluid passage is opened or closed (vented or applied), depending on its default operating state. The result is an apply or release of a friction element. Refer to the chart in Figure 3.

SOLENOID APPLICATION CHART							
	N.V.	N.A.	N.V.	N.V.	N.V.	N.A.	N.V.
SELECTOR POSITION	LR/CC SOLENOID	UD SOLENOID	OD SOLENOID	2nd CLUT SOLENOID	4th CLUT SOLENOID	Multi-Select SOLENOID	Line Pressure SOLENOID
Park/Neutral	ON					ON	Modulating
Park/Neutral	ON					ON	Modulating
REVERSE	ON					***OFF	Modulating
OD-1ST	*ON	ON				ON	Modulating
OD-2ND	**	ON		ON		ON	Modulating
OD-3RD	**	ON			ON	ON	Modulating
OD-4TH	**	ON	ON			OFF	Modulating
OD-5TH	**		ON		ON	OFF	Modulating
OD-6TH	**		ON	ON		ON	Modulating
(1)-1ST Or Autostick	ON	ON				ON	Modulating
FAILSAFE	OFF	OFF	OFF	OFF	OFF	OFF	OFF

* L/R Clutch is on only with the output shaft speed below 150 RPM. N.V. = Normally Vented

**Modulating (EMCC) if the Converter Clutch has been signaled. N.A. = Normally Applied

***Off Below 8 MPH, On Above 8 MPH.

Copyright © 2011 ATSG

Figure 3



Technical Service Information

ELECTRICAL OPERATION

Transmission Control Module (TCM)

Vehicles equipped with the 68RFE and a 6.7L Diesel engine use a Transmission Control Module (TCM) housed in the New Generation Controller (NGC) utilizing only the C1 and C4 connectors. The TCM controls *all* of the transmission functions. The controller is located at the rear of the engine compartment, near the right inner fender, as shown in Figure 12. The Powertrain Control Module (PCM) *does not* control the transmission. The electronic components of the 68RFE transmission consist of various sensors and switches as input information to the TCM, that the TCM uses to determine the appropriate gear ratio and shift schedule points. There is also the associated wiring, fuses, relays, connectors, splices and grounds for the transmission to function as designed. A complete transmission wiring schematic has been provided for you in Figure 10.

The final output from the TCM is to the six shift solenoids and the line pressure control solenoid located in the Solenoid Body/Transmission Range Sensor assembly and bolted on the valve body as shown in Figure 9. The solenoids in this transmission are unique in that some are normally vented and some are normally applied and this is also illustrated in Figure 9. The TCM also communicates with other control modules, such as the PCM, and the New Generation Controller (NGC) modules currently use PCI or CAN C bus.

The TCM receives power from two sources, fused battery power to pin 18 (C4 connector) and fused ignition switch input to pin 30 (C1 connector). The TCM also has several grounds to complete its electrical circuit, as shown in Figure 10.

ADAPTIVE LEARNING

The 68RFE transmission uses an "Adaptive Learning" feature which allows the TCM to modify the clutch apply rate to maintain consistent shift quality. This is done based on the amount of wear on the friction elements. The TCM then adjusts the duty cycle of the shift solenoids to achieve the smoothest possible upshifts and downshifts. The TCM adjusts the "Clutch Volume Index" when a shift change takes place to optimize clutch to clutch timing. Clutch Volume Index is described on Page 16, along with proper clutch volumes and clutch clearances for the 68RFE transmission shown in Figure 15.

LIMP-IN MODE OPERATION

The TCM has the ability to monitor all transmission related electrical components and if it detects a problem, takes appropriate action, and most of the time results in the TCM setting a Diagnostic Trouble Code (DTC). Whether this results in MIL illumination, or Limp-in Mode operation, depends on the type of DTC that was set.

If the TCM determines that transmission damage may result from the DTC type that was set, the TCM will shut off the ground signal to the transmission control relay which will shut off all power to the transmission and the vehicle will be in Limp-in Mode Operation.

When in Limp-in Mode Operation, with the shift lever in the "Drive" position the transmission will be in 4th gear, and if the shift lever is moved to "2" or "L" position the transmission will be in 2nd gear. This will allow the driver to manually shift the transmission to Limp home.

Note: Vehicles equipped with Electronic Range Select (ERS) do not provide 2nd gear limp-in, because the shift lever has no "2" or "1" shift lever positions.

The hydraulic control system design, without any electronic assist, provides the 68RFE transmission with PARK, REVERSE, NEUTRAL, and FOURTH gears based solely on driver selection. This design allows the vehicle to be driven in "limp-in" mode (4th gear) in the event of a total electronic control system failure, or a situation that the TCM recognizes as potentially damaging to the transmission (DTC Stored).

INPUTS TO THE TCM

Input and Output Shaft Speed Sensors - are located on the left side of the transmission and are illustrated in Figure 5. The input shaft speed sensor reads input shaft speed off of a tone wheel on the input clutch housing. As the teeth of the tone wheel pass the sensor coil, an AC voltage is generated and sent to the TCM. The TCM interprets this information as input shaft rpm.

The output speed sensor generates an AC signal in a similar fashion, though its coil is excited by rotation of the parking gear teeth. The TCM interprets this information as output shaft rpm.

The TCM compares the input and output speed signals to determine the following:

- Transmission gear ratio.
- Speed ratio error detection.
- Clutch Volume Index calculation.
- Torque Converter Clutch slippage.

Both speed sensors are the same and will interchange. New speed sensors, when checked for resistance, read 535 ohms at room temperature.

Pressure Switches - are located inside the solenoid and pressure switch assembly and are only serviced by replacing the complete solenoid/TRS assembly. The TCM relies on five pressure switches to monitor pressure in the Low/Rev, 2nd Clutch, 4th Clutch, Underdrive, and Overdrive hydraulic circuits. The primary function of these switches is to help the TCM detect when clutch circuit hydraulic failures occur. The switches close at 23 psi and open at 11 psi, and indicate whether or not pressure exists. The switches are continuously monitored by the TCM for the proper states (Open or Closed) in each gear, shown in the chart in Figure 4.

68RFE PRESSURE SWITCH CHART					
	Low/Rev	2nd Clut	4th Clut	Underdrive	Overdrive
Park/Neut	Closed	Open	Open	Open	Open
Reverse	Open	Open	Open	Open	Open
First	Closed*	Open	Open	Closed	Open
Second	Open	Closed	Open	Closed	Open
Third	Open	Open	Closed	Closed	Open
Fourth	Open	Open	Open	Closed	Closed
Fifth	Open	Open	Closed	Open	Closed
Sixth	Open	Closed	Open	Closed	Closed

* L/R is closed if output speed is below 150 RPM in Drive and Manual 2.
L/R is open in Manual 1.

Copyright © 2011 ATSG

Figure 4

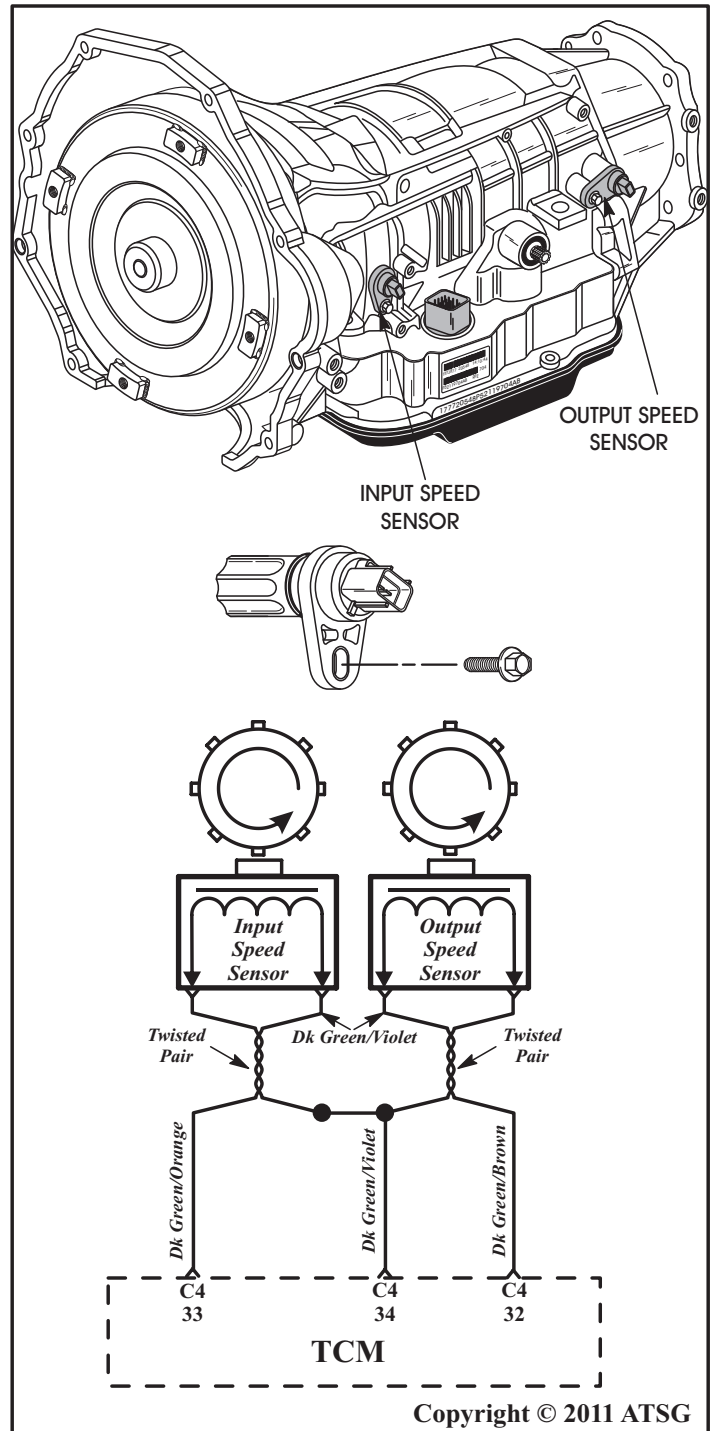

Figure 5

Inputs To The TCM
Continued on Page 8